

SLite Rental Structure



Barco's SLite rental structure has been purpose built to facilitate the fast, easy build-up and break-down of an SLite LED display. With its light-weight, slim profile design and easy-to-use locking mechanisms, the SLite rental structure is ideal for use in rental & staging applications.

The SLite flightcase, which holds four SLite rental structures (with tiles) per case, is equipped with heavy-duty locks and ultra-hard wearing polyurethane castors to withstand the most demanding of rental environments. A specially designed trolley system also enables build up of the display directly from the flightcase.

IVS TECHNOLOGIES

www.ivstechnologies.com
ZI La Montjoie
1, rue des Drapiers
93210 LA PLAINE SAINT-DENIS
Tél. +33 (0)1 55 93 48 48
Fax: +33 (0)1 55 93 48 49



SLite Rental Structure specifications

• Width Structure	896mm
• Height Structure	672mm
• Depth Structure	249mm with S10: 255mm with S14
• Width Flightcase	1440mm
• Height Flightcase	980mm
• Depth Flightcase	960mm
• Weight Frame	15kg
• Weight Frame (including tile)	49kg
• Weight Flightcase	142kg
• Weight Flightcase (including 4 tiles)	340kg
• Truss build-up	8 tiles high
• Foot build-up (with Stacker)	9 tiles high
• Accessibility & Servicing	Front and rear access for tile
• Flightcase	Stackable Forklift slots Heavy-duty locks Heavy-duty polyurethane castors
• TUV approved for safety	

Other mechanics

• Foot assemblies	One per column of tiles (2.4m or 4m)
• Stacker Assemblies	Required between each column of tiles when floor mounted
• Truss beams	Single or dual tile width

Dimensions

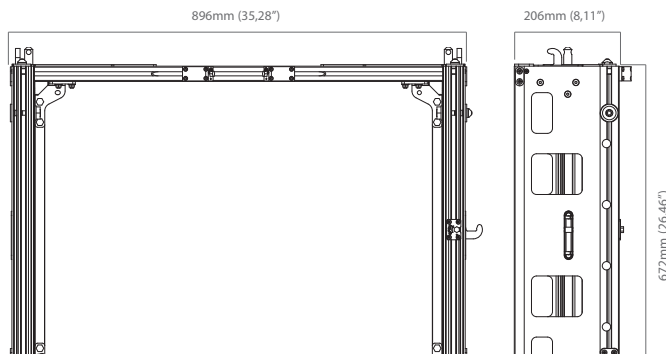

IVS TECHNOLOGIES

www.ivstechnologies.com

ZI La Montjoie

1, rue des Drapiers

93210 LA PLAINE SAINT-DENIS

Tél. +33 (0)1 55 93 48 48

Fax: +33 (0)1 55 93 48 49

